

DATA SHEET

THIN FILM CHIP RESISTORS AUTOMOTIVE GRADE

NT series

0.1% TO 1%, TC25 TO TC50
sizes 0402/0603/0805/1206

RoHS compliant



SCOPE

This specification describes NT0402 to NT1206 high precision-high stability chip resistors made by thin film process.

APPLICATIONS

- Automotive electronics
- Industrial and medical equipment
- Test and measuring equipment
- Telecommunications

FEATURES

- AEC-Q200 qualified
- Pb free without RoHS exemption
- Halogen free epoxy
- Superior resistance against sulfur containing surroundings
- Moisture sensitivity level: MSL I
- Environmental hazards Reduction
- Non-forbidden materials used in products / production

ORDERING INFORMATION - GLOBAL PART NUMBER

Part number is identified by the series name, size, tolerance, packaging type, temperature coefficient, taping reel and resistance value.

GLOBAL PART NUMBER

NT XXXX X X X XX XXXXX L
 (1) (2) (3) (4) (5) (6) (7)

(1) SIZE

0402 / 0603 / 0805 / 1206

(2) TOLERANCE

- B = ± 0.1%
- C = ± 0.25%
- D = ± 0.5%
- F = ± 1%

(3) PACKAGING TYPE

R = Paper taping reel

(4) TEMPERATURE COEFFICIENT OF RESISTANCE

- D = ± 25 ppm/°C
- E = ± 50 ppm/°C

(5) TAPING REEL

07 = 7 inch dia. Reel

(6) RESISTANCE VALUE

There are 2~4 digits indicated the resistor value.
 Letter R/K/M is decimal point
 Example: 100R = 100Ω
 1K = 1,000Ω

(7) DEFAULT CODE

Letter L is the system default code for ordering only. (NOTE)

ORDERING EXAMPLE

The ordering code of a NT0402 chip resistor, TCR 50 value 100Ω with ±0.5% tolerance, supplied in 7-inch tape reel is: NT0402DRE07100RL.

NOTE

1. All our Rchip products meet RoHS compliant and Halogen Free. "LFP" of the internal 2D reel label mentions "Lead Free Process".
2. On customized label, "LFP" or specific symbol can be printed.

MARKING

NT0402

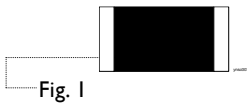

No marking

NT0603

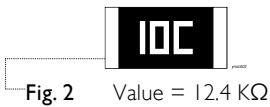

E-96 series: including values 10/11/13/15/20/75 of E-24 series, 3 digits

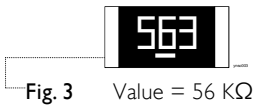

E-24 series: exception values 10/11/13/15/20/75 of E-24 series, one short bar under marking letter

NT0805 / NT1206

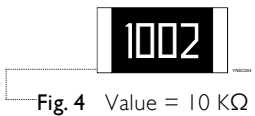

Both E-24 and E-96 series: 4 digits
First three digits for significant figure and 4th digit for number of zeros

NOTE

For further marking information, please see special data sheet “Chip resistors marking”.

CONSTRUCTION

The resistors are constructed out of a high grade ceramic body. Internal metal electrodes are added at each end connected by a resistive layer. This resistive layer is trimmed to its nominal value and on both ends a contact is made which will guarantee optimum solderability. This is achieved by applying several layers and for ease of soldering the outer layer consists of Ni/matte tin. Adding a special protective coating, on this series to enhance moisture resistance of the environment.

OUTLINES

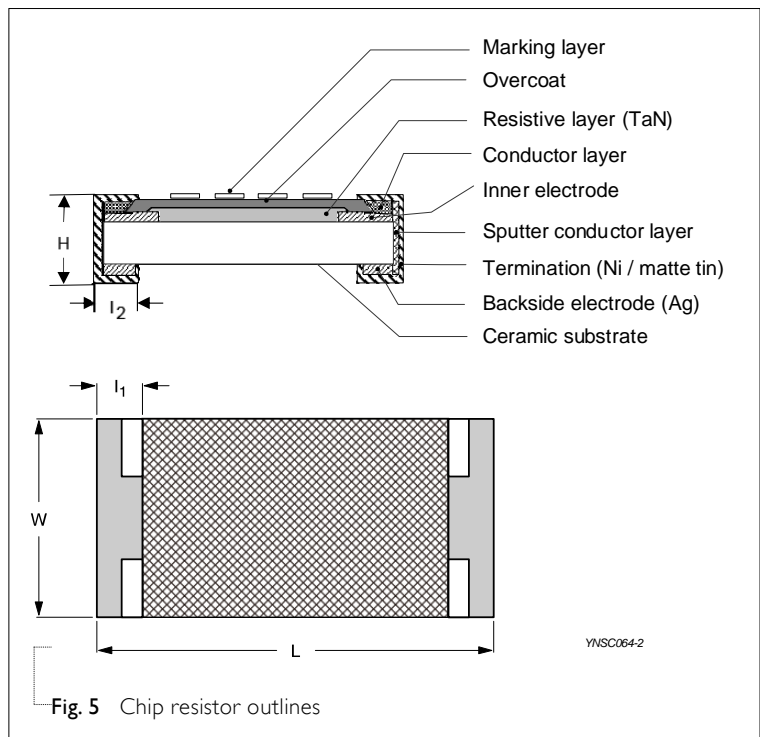

Fig. 5 Chip resistor outlines

DIMENSIONS

Table 1

| TYPE | L (mm) | W (mm) | H (mm) | l ₁ (mm) | l ₂ (mm) |
|--------|------------|------------|------------|---------------------|---------------------|
| NT0402 | 1.00 ±0.10 | 0.50 ±0.05 | 0.30 ±0.05 | 0.20 ±0.10 | 0.25 ±0.10 |
| NT0603 | 1.60 ±0.10 | 0.80 ±0.10 | 0.45 ±0.10 | 0.25 ±0.15 | 0.25 ±0.15 |
| NT0805 | 2.00 ±0.10 | 1.25 ±0.10 | 0.50 ±0.10 | 0.35 ±0.20 | 0.35 ±0.20 |
| NT1206 | 3.10 ±0.10 | 1.60 ±0.10 | 0.55 ±0.10 | 0.45 ±0.20 | 0.40 ±0.20 |

ELECTRICAL CHARACTERISTICS

Table 2

| TYPE | Operating Temperature Range | Power Rating | Max. Working Voltage | Max. Overload Voltage | Resistance Range (E-24/E-96 series)(Ω) & Tolerance ⁽¹⁾ | | | | |
|--------|-----------------------------|--------------|----------------------|-----------------------|---|----------------|------------|-----------|---------|
| | | | | | T.C.R. (ppm/°C) ⁽²⁾ | ±0.1% (B) | ±0.25% (C) | ±0.5% (D) | ±1% (F) |
| NT0402 | -55 °C to +155 °C | 1/20W | 75 V | 150 V | ±50 (E) ±25 (D) | 100 ≤ R ≤ 63K4 | | | |
| NT0603 | | 3/20W | 75V | 150 V | ±50 (E) ±25 (D) | 100 ≤ R ≤ 189K | | | |
| NT0805 | | 1/5W | 150 V | 300 V | ±50 (E) ±25 (D) | 100 ≤ R ≤ 370K | | | |
| NT1206 | | 2/5W | 200 V | 400 V | ±50 (E) ±25 (D) | 100 ≤ R ≤ 481K | | | |

NOTE : 1. Global part number (code 7)
2. Global part number (code 9)

FOOTPRINT AND SOLDERING PROFILES

For recommended footprint and soldering profiles, please see the special data sheet “Chip resistors mounting”.

PACKING STYLE AND PACKAGING QUANTITY

Table 3 Packing style and packaging quantity

| PRODUCT TYPE | PATKING STYLE | REEL DIMENSION | QUANTITY PER REEL |
|--------------|-------------------|----------------|-------------------|
| NT0402 | Paper taping reel | 7" (178 mm) | 10,000 Units |
| NT0603 | Paper taping reel | 7" (178 mm) | 5,000 Units |
| NT0805 | Paper taping reel | 7" (178 mm) | 5,000 Units |
| NT1206 | Paper taping reel | 7" (178 mm) | 5,000 Units |

NOTE: for paper tape and reel specification/dimensions, please see the special data sheet “packing” document.

FUNCTIONAL DESCRIPTION

OPERATING TEMPERATURE RANGE

Range: -55 °C to +155 °C

POWER RATING

Each type rated power at 70 °C:

- NT0402=1/20W
- NT0603=3/20W
- NT0805=1/5W
- NT1206=2/5W

RATED VOLTAGE

The DC or AC (rms) continuous working voltage corresponding to the rated power is determined by the following formula:

$$V = \sqrt{(P \times R)}$$

Or max. working voltage whichever is less

Where

V=Continuous rated DC
or AC (rms) working voltage (v)

P=Rated power

R=Resistance value (Ω)

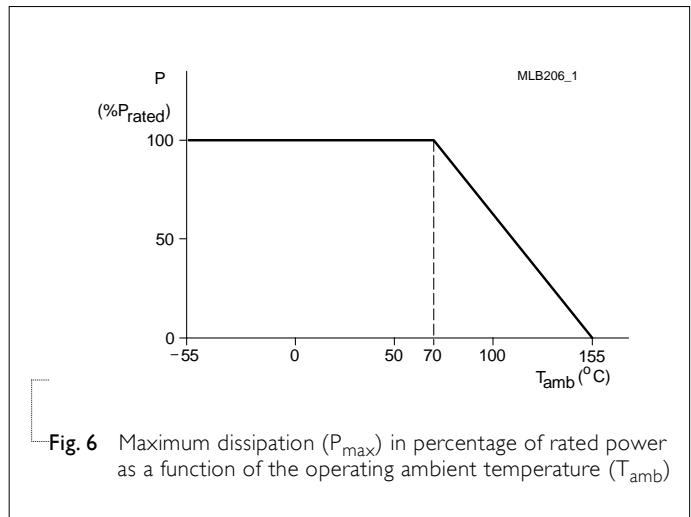

Fig. 6 Maximum dissipation (P_{max}) in percentage of rated power as a function of the operating ambient temperature (T_{amb})

TESTS AND REQUIREMENTS

Table 4 Test condition, procedure and requirements

| TEST | TEST METHOD | PROCEDURE | REQUIREMENTS |
|------------------------------|--|--|--|
| Short Time Overload | IEC60115-1 4.13 | 2.5 times of rated voltage or maximum overload voltage, the less of the above, for 5 sec at room temperature | $\pm(0.05\%+0.05\Omega)$ |
| High Temperature Exposure | AEC-Q200 Test 3 MIL-STD-202 Method 108 | 1,000 hours at Tamb = 155 °C, unpowered | $\pm(0.3\%+0.05\Omega)$ |
| Moisture Resistance | AEC-Q200 Test 6 MIL-STD-202 Method 106 | Each temperature / humidity cycle is defined at 8 hours (method 106F), 3 cycles / 24 hours for 10d. with 25 °C / 65 °C 95% R.H, without steps 7a & 7b, unpowered Parts mounted on test-boards, without condensation on parts | $\pm(0.1\%+0.05\Omega)$ |
| Biased Humidity | AEC-Q200 Test 7 MIL-STD-202 Method 103 | 1,000 hours; 85 °C / 85% RH 10% of operating power Measurement at 24±4 hours after test conclusion | $\pm(0.1\%+0.05\Omega)$ |
| Life | AEC-Q200 Test 8 MIL-STD-202 Method 108 | 1,000 hours at 70±5 °C, RCWV applied for 1.5 hours on, 0.5 hour off, still air required | $\pm(0.1\%+0.05\Omega)$ |
| Resistance to Soldering Heat | AEC-Q200 Test 15 MIL-STD-202 Method 210 | Condition B, no pre-heat of samples Lead-free solder, 260±5 °C, 10±1 seconds immersion time Procedure 2 for SMD: devices fluxed and cleaned with isopropanol | $\pm(0.05\%+0.05\Omega)$ |
| Thermal Shock | AEC-Q200 Test 16 MIL-STD-202 Method 107 | -55/+125 °C Number of cycles is 300. Devices mounted Maximum transfer time is 20 seconds. Dwell time is 15 minutes. Air – Air | $\pm(0.1\%+0.05\Omega)$ No visible damage |
| Solderability - Wetting | AEC-Q200 Test 18 J-STD-002 | Electrical Test not required Magnification 50X SMD conditions: (a) Method B, aging 4 hours at 155 °C dry heat, dipping at 235±3 °C for 5±0.5 seconds. (b) Method B, steam aging 8 hours, dipping at 215±3 °C for 5±0.5 seconds. (c) Method D, steam aging 8 hours, dipping at 260±3 °C for 7±0.5 seconds | Well tinned (>95% covered) No visible damage |

| TEST | TEST METHOD | PROCEDURE | REQUIREMENTS |
|--|----------------------------------|---|------------------|
| Board Flex / Bending | AEC-Q200 Test 21 AEC-Q200-005 | Chips mounted on a 90mm glass epoxy resin PCB (FR4) Bending for 0402: 5 mm 0603/0805: 3 mm 1206: 2mm Holding time: minimum 60 second | ±(0.1%+0.05Ω) |
| Temperature Coefficient of Resistance (T.C.R.) | IEC 60115-1 4.8 | At +25/-55 °C and +25/+125°C Formula: $T.C.R = \frac{R2 - R1}{R1 (t2 - t1)} \times 10^6 (\text{ppm}/^\circ\text{C})$ <p>Where t1 = +25 °C or specified room temperature t2 = -55 °C or +125 °C test temperature R1 = resistance at reference temperature in ohms R2 = resistance at test temperature in ohms</p> | Refer to table 2 |
| Flower of Sulfur | ASTM-B-809-95* * Modified | Sulfur 750 hours, 105°C, unpowered. | ±(2.0%+0.05Ω) |

REVISION HISTORY

| REVISION | DATE | CHANGE NOTIFICATION | DESCRIPTION |
|-----------|---------------|---------------------|-------------------------------------|
| Version 0 | Oct. 31, 2023 | - | - First issue of this specification |

LEGAL DISCLAIMER

YAGEO, its distributors and agents (collectively, "YAGEO"), hereby disclaims any and all liabilities for any errors, inaccuracies or incompleteness contained in any product related information, including but not limited to product specifications, datasheets, pictures and/or graphics. YAGEO may make changes, modifications and/or improvements to product related information at any time and without notice.

YAGEO makes no representation, warranty, and/or guarantee about the fitness of its products for any particular purpose or the continuing production of any of its products. To the maximum extent permitted by law, YAGEO disclaims (i) any and all liability arising out of the application or use of any YAGEO product, (ii) any and all liability, including without limitation special, consequential or incidental damages, and (iii) any and all implied warranties, including warranties of fitness for a particular purpose, non-infringement and merchantability.

YAGEO products are designed for general purpose applications under normal operation and usage conditions. Please contact YAGEO for the applications listed below which require especially high reliability for the prevention of defects which might directly cause damage to the third party's life, body or property: Aerospace equipment (artificial satellite, rocket, etc.), Atomic energy-related equipment, Aviation equipment, Disaster prevention equipment, crime prevention equipment, Electric heating apparatus, burning equipment, Highly public information network equipment, data-processing equipment, Medical devices, Military equipment, Power generation control equipment, Safety equipment, Traffic signal equipment, Transportation equipment and Undersea equipment, or for any other application or use in which the failure of YAGEO products could result in personal injury or death, or serious property damage. Particularly **YAGEO Corporation and its affiliates do not recommend the use of commercial, automotive, and/or COTS grade products for high reliability applications or manned space flight.**

Information provided here is intended to indicate product specifications only. YAGEO reserves all the rights for revising this content without further notification, as long as products are unchanged. Any product change will be announced by PCN.