

SOT26-001

Time-of-Flight Sensor

Datasheet

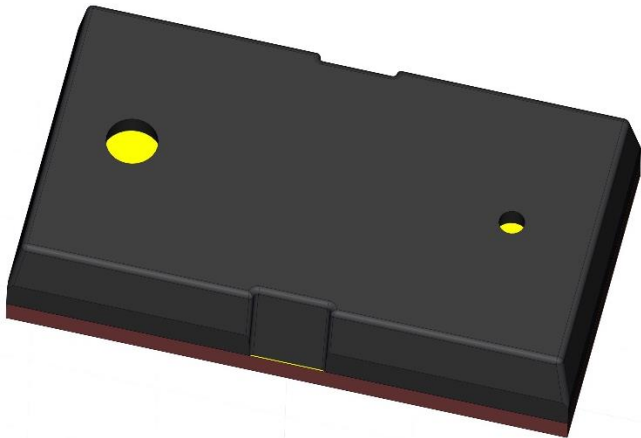

Index

1. General description	5
1.1 Technical specifications	6
1.2 System block diagram	6
1.3 Pin definition	7
2. Electrical characteristics	7
2.1 Absolute maximum ratings	7
2.2 Recommended operating conditions	8
2.3 ESD performance	8
2.4 Current consumption	8
3. Typical ranging characteristics	8
3.1 Ranging Time	8
3.2 Ranging characteristics	8
4. Functional description	10
4.1 Firmware state machine description	10
4.2 Ranging offset calibration	10
4.3 Ranging operating modes	11
4.4 Getting the data: interrupt or polling	11
4.5 Power sequence	11
4.6 MCU Parameters	12
4.7 I2C Control interface	12
4.7.1 IIC Overview	12
4.7.2 IIC Transmission Protocol	13
4.7.3 IIC Write process	13
4.7.4 IIC Read process	14
5. Registers Description	15
5.1 General Registers	15
5.2 Registers in Bootloader mode	15
5.3 Registers in APP0 mode	16
6. Application information	18
6.1 Module dimensions	18
6.2 PCB pad layout	18

- 6.3 Application schematic 19
- 7. Soldering and storage..... 19**
 - 7.1 Manufacturing and soldering..... 19
 - 7.2 Storage information..... 20
- 8. Package Specifications..... 22**
 - 8.1 Tape Specifications 22
 - 8.2 Reel Specification 23
 - 8.3 The content of Box 23
 - 8.4 Packing Explain..... 24
- 9. Laser eye safety..... 25**
- 10. Acronyms and abbreviations 25**

1. General description

The SOT26-001 is a highly integrated, compact single-point direct Time-of-Flight (dToF) sensor module which integrates a VCSEL emitter, a single photon avalanche diode (SPAD) sensor, microlens, Time Digital Converter (TDC) and MCU. This sensor uses dTOF technology, built-in sunlight suppression and anti-cover dirt algorithm, the measurement accuracy is not affected by reflectivity of the target object in different environments, and can achieve accurate ranging of up to 4m.

The sensor supports Firmware updates through the IIC, can be customized according to customer's requirements model and algorithm. The sensor is designed with eye safety control circuit, which meets the requirements of Class I eye safety standard.

Features

- Fully integrated SIP module
 - Transmit and receive integration
 - Package: Optical LGA
 - Size: 4.4×2.4×1.0 mm
- Distance measurement
 - Range: up to 5 m
 - Ranging rate: up to 50 Hz
 - Measurement accuracy: ±3%
- Optics
 - Class 1 laser device
 - 940 nm VCSEL emitter
- Characteristics
 - Direct time-of-flight measurement
 - On-chip histogram based algorithm
 - Eliminate crosstalk
 - Support multiple cover glass
 - Cover glass calibration
 - Dynamic compensation for smudge on glass
- Interface and work environment
 - IIC interface
 - Extremely low power consumption in sleep mode
 - Operation Temperature: -20~70°C
 - Good temperature stability
 - Compliant with ROHS and REACH regulations

Applications

- Distance measurement for camera autofocus (LDAF)
- Proximity detection
- Collisions avoidance
- 1D gesture recognition
- Object detection supporting low-power system operation

1.1 Technical specifications

Table 1: Technical specifications

Parameter	Value
Range	2 cm ~ 5 m
Measurement accuracy	±3% @ indoors
FOI (Field of illumination)	22 deg
FOV (Field of View)	25°
Wavelength	940 nm
Size	4.4 mm x 2.4 mm x 1.0 mm
Ranging rate	Up to 50 Hz
Operating voltage	3.3 V
Operating current	0.9 mA @1 Hz, 17 mA @30 Hz
Standby Power Consumption	<10µA @ HW STANDBY
Number of interface	OLGA 12
Interface type	IIC, Slave address: (0x41)
Operating temperature	-20°C ~ 70°C
Storage temperature	-40~85°C
Laser eye safety	LASER CLASS 1 (IEC 60825-1: 2014)

1.2 System block diagram

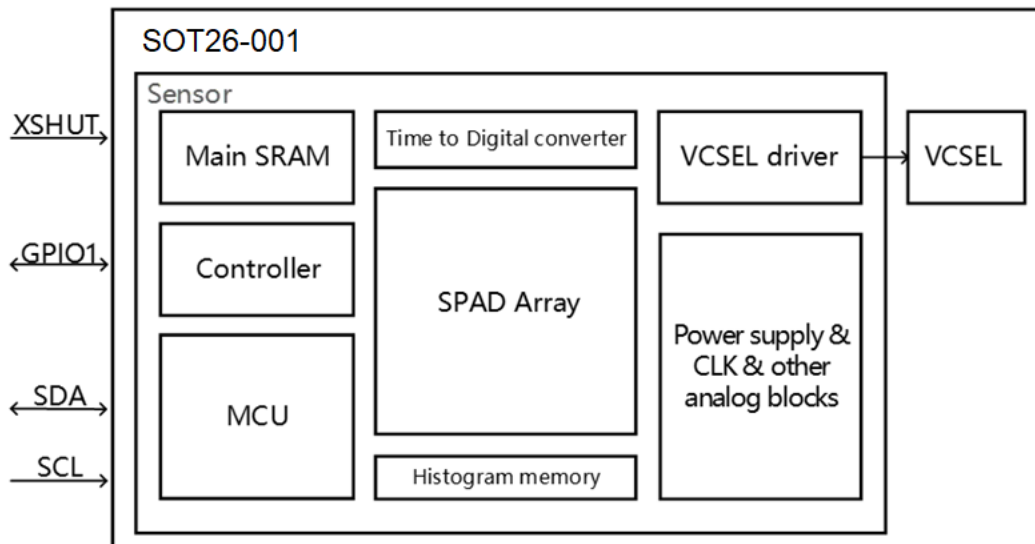

Figure 1: System block diagram

1.3 Pin definition

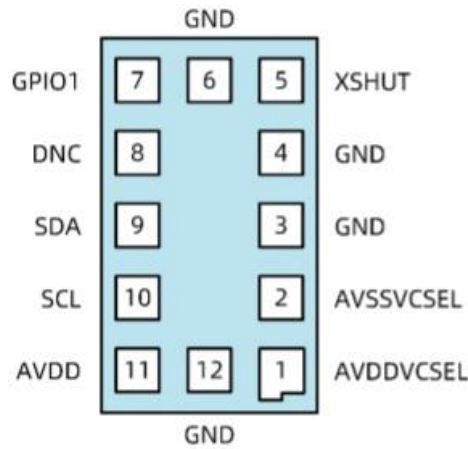

Figure 2: Pin out diagram (bottom view)

Table 2: Pin definition

Pin No.	Pin name	Signal type	Description
1	AVDDVCSEL	Supply	3.2 V ~ 3.6 V DC
2	AVSSVCSEL	Ground	To be connected to ground
3	GND	Ground	To be connected to ground
4	GND2	Ground	To be connected to ground
5	XSHUT	Digital input	Hardware reset pin, active low
6	GND3	Ground	To be connected to ground
7	GPIO1	Digital input/output	Default output low, floating when not in use
8	DNC	-	Leave this pin floating
9	SDA	Digital input/output	I ² C serial data
10	SCL	Digital input	I ² C serial clock input
11	AVDD	Supply	3.2 V ~ 3.6 V DC
12	GND4	Ground	To be connected to ground

2. Electrical characteristics

2.1 Absolute maximum ratings

Table 3: Absolute maximum ratings

Parameter		Min.	Typ.	Max.	Unit
AVDD,AVDDVCSEL	Supply (3.3V)	-0.5	-	3.63	V
GND,GND2,GND3,GND4	Connected to ground	0	-	0	V
XSHUT,SDA,SCL,GPIO1	Digital input/output (1.8V Mode)	-0.5	-	1.98	V
	Digital input/output (3.3V Mode)	-0.5	-	3.63	V

2.2 Recommended operating conditions

Table 4: Recommended operating conditions

Parameter		Min.	Typ.	Max.	Unit
AVDD,AVDDVCSEL	Voltage (3.3V)	2.97	3.3	3.63	V
Temperature	Normal operating	-20	25	70	°C

2.3 ESD performance

Table 5: ESD performance

Parameter		Conditions	Specification
I _{SCR}	Latch up immunity	+/- 100mA	JEDEC78E
V _{ESD,HBM}	ESD HBM Model	+/- 2000V	JS-001-2017
V _{ESD,CDM}	ESD CDM Model	+/- 500V	JS-002-2018

2.4 Current consumption

Table 6: Consumption at ambient temperature

Parameter		Min.	Typ.	Max.	Unit
HW STANDBY	Close Xshut	-	-	10	µA
SW STANDBY	Open Xshut	-	-	20	µA
Average Power Consumption	@ 30Hz, Including VCSEL	-	-	56.1	mW

3. Typical ranging characteristics

3.1 Ranging Time

The ranging time is directly related to the number of times VCSEL light pulses and the maximum test distance. The farther the test distance, the more light pulses required and the longer the ranging time.

3.2 Ranging characteristics

The following ranging performance is measured under conditions such as glass transmittance of 90%, the Air-Gap is 0.36mm, and without backlight.

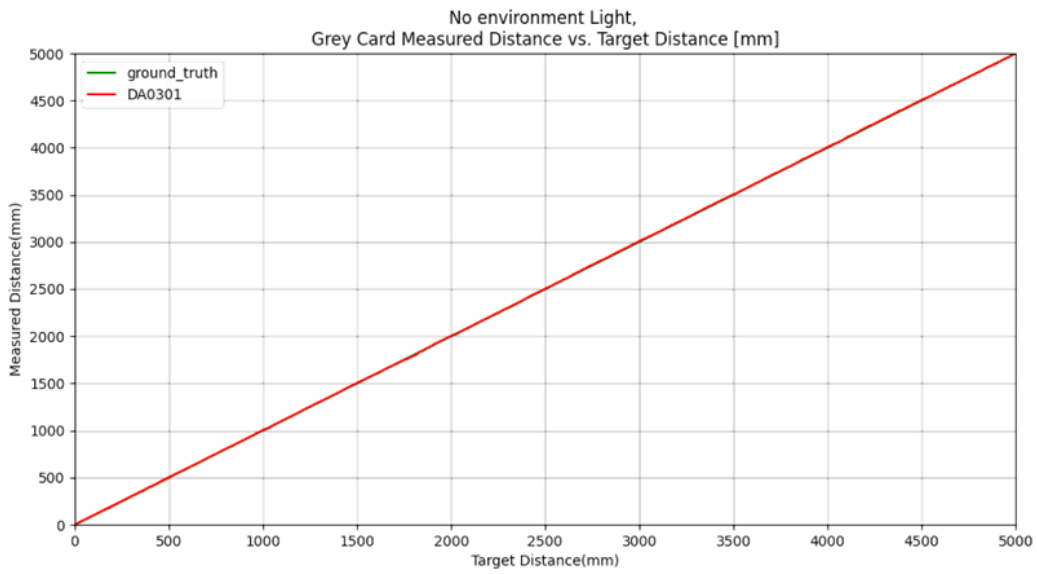

Figure 3 Ranging curve without ambient light

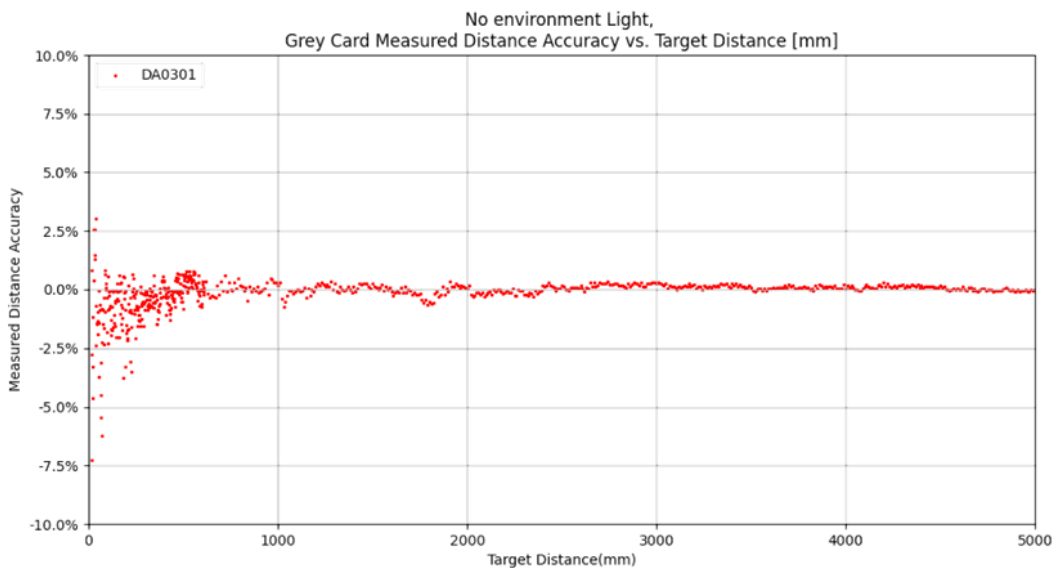

Figure 4 Accuracy in ambient light

Table 7 Range and Accuracy

Test Conditions		Max ranging distance	Accuracy	Precision
Indoor (0klux)	White target (90%)	5m	± 15mm @20~300mm ± 3% @>300mm	<15mm
	Grey target (18%)	4.3m	± 12mm @20~300mm ± 3% @>300mm	<15mm
Outdoor (15klux)	White target (90%)	1.8m	± 20mm @20~300mm ± 4% @>300mm	12mm +1%
	Grey target (18%)	1.3m	± 15mm @20~300mm ± 4% @>300mm	12mm +1%

4. Functional description

4.1 Firmware state machine description

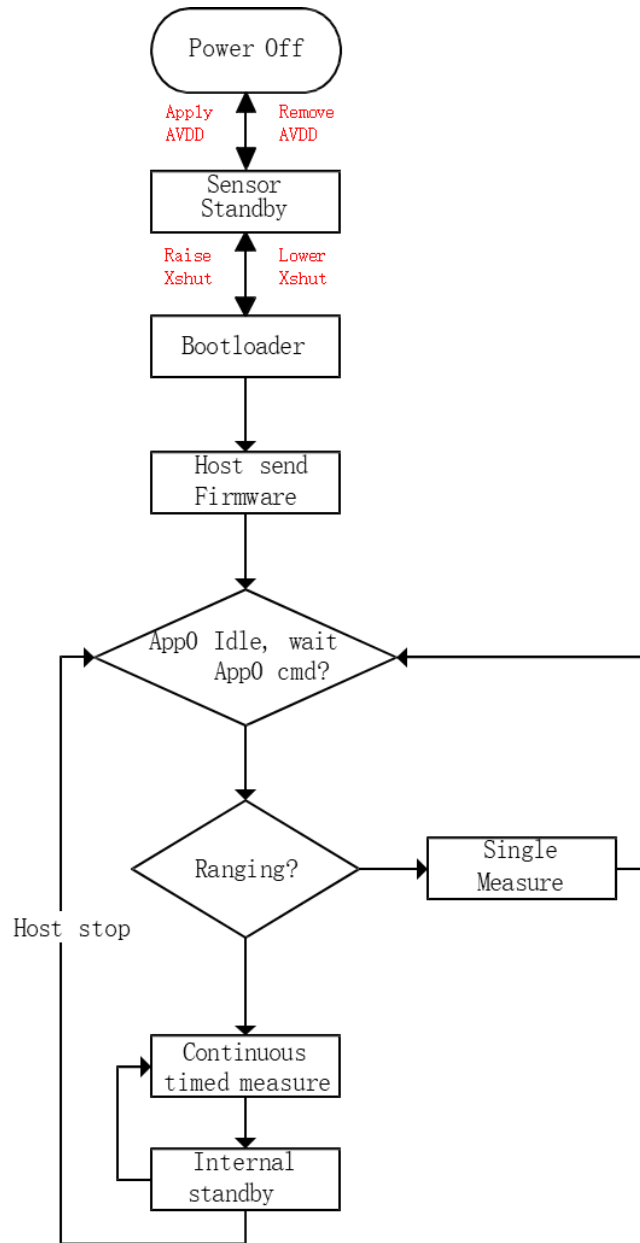

Figure 5 Firmware state machine

4.2 Ranging offset calibration

Offset calibration should be performed at factory for optimal performances (recommended at 50 cm). The offset calibration should take into account:

- Supply voltage and temperature
- Protective cover glass above SOT26-001

4.3 Ranging operating modes

There are 3 ranging modes available in this module:

1. Single ranging

Ranging is performed only once. System returns to SW standby automatically.

2. Timing mode

HOST can customize the measurement interval. When the timing measurement is initiated, the sensor generates a distance measurement interruption at corresponding intervals. If the HOST needs the sensor to enter SW standby, it needs to send a stop command. If the stop request comes during a range measurement, the measurement is completed before stopping and system returns to SW standby. If it happens during an inter-measurement period, the range measurement stops immediately.

3. Continuous ranging

HOST specifies the number of frames to measure. After the ranging is complete, system returns to SW standby automatically.

4.4 Getting the data: interrupt or polling

User can get the final data using a polling or an interrupt mechanism.

Polling mode: The user drives the interrupt flag bits of the interrupt register (0xE1). When the interrupt flag bit is set to 1, the measurement result can be read and the interrupt flag bit written to 1 to clear the interrupt.

Interrupt mode: The interrupt pin (GPIO1) defaults to high. When the ranging result is updated, the interrupt pin is pulled low, resulting in a falling edge. HOST needs to write 1 to the interrupt flag bit to clear the interrupt, and the interrupt pin is reset high.

4.5 Power sequence

Option 1: XSHUT pin connected and controlled from host. After XSHUT is enabled, the IC module can accept the boot configuration from the HOST. After the configuration is complete, the BootLoader phase will be entered, after which the firmware (FW) upload and register initialization will be performed. The sensor enters software standby and waits for the HOST to send instructions.

Option 2: When the ranging command is received, the ranging work is entered. When a frame of testing completes, an interrupt is generated (GPO1). After HOST detects an interrupt, it accesses the result register through IIC, and the interrupt must be cleared manually after the read is completed.

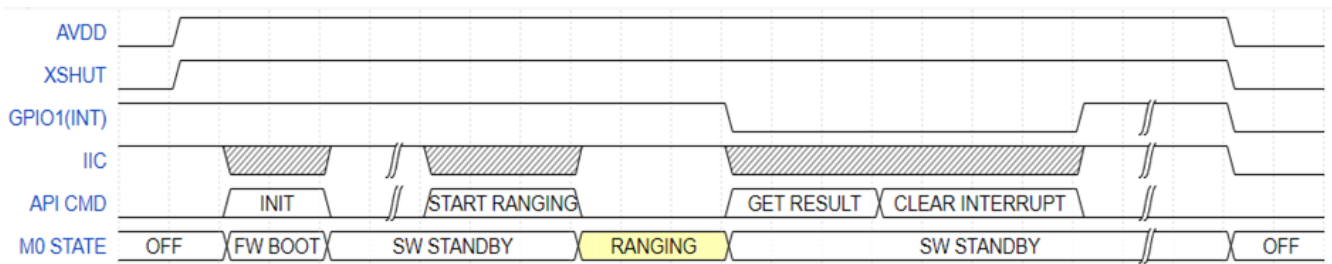

Figure 6 Power up and boot sequence

4.6 MCU Parameters

SOT26-001 contains an ARM-Cortex M0 MCU. The relevant parameters are shown in the table.

Table 8: MCU Parameters

Parameter	Min.	Typ.	Max.	Unit	Remark
μP Operating frequency	-	5	80	MHz	MCU can operate using an oscillator or PLL clock.
PLL frequency	-	80	--	MHz	Corresponding to a 5MHz oscillator clock

4.7 I2C Control interface

4.7.1 IIC Overview

The IIC interface is used to transfer information between SOT26-001 and other chips. IIC is short for Inter-IC, also known as I²C, a simple bidirectional two-wire bus developed by Philips for effective interconnect control between ICs. It includes a bidirectional data line SDA and a clock line SCL. As shown in the figure, multiple master devices and multiple slave devices' SDA and SCL can be connected separately, and each device can be distinguished by its unique address. SOT26-001 is an IIC slave device that receives and processes read and write requests sent by the master.

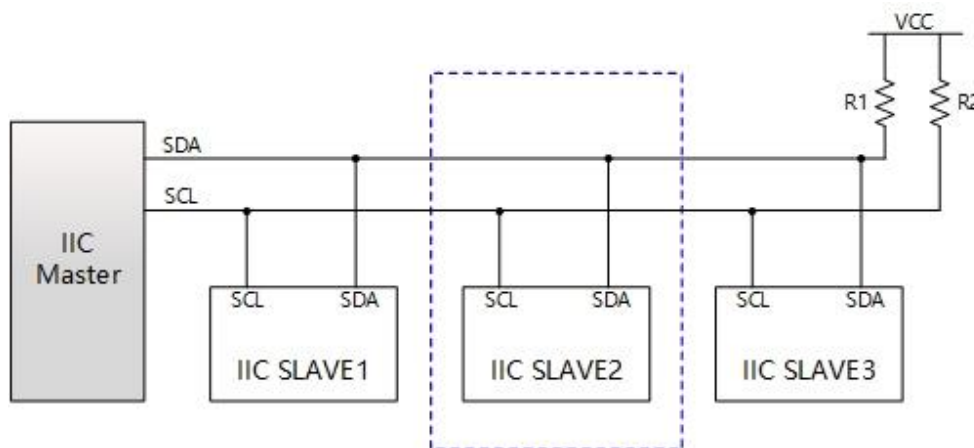

Figure 7 Power-on startup timing

The device address of SOT26-001 is 0x41 (when adding 1 bit read/write to form 8-bit, the byte data is 0x82), and the highest supported transmission speed is 1Mbits/s.

4.7.2 IIC Transmission Protocol

IIC is a master-slave serial transmission protocol, where signal transmission is composed of a clock line SCL and a bidirectional data line SDA. All transmission operations are initiated by the master, and the slave executes read and write operations according to the timing sequence composed of SCL and SDA. The timing protocol consists of four parts: start signal, bit transmission, ACK confirmation bit, and end signal. The bit transmission can be the transmission of slave address and read/write identification, register address transmission, or read/write data bit transmission, all of which are serial transmissions.

Start and End Signals

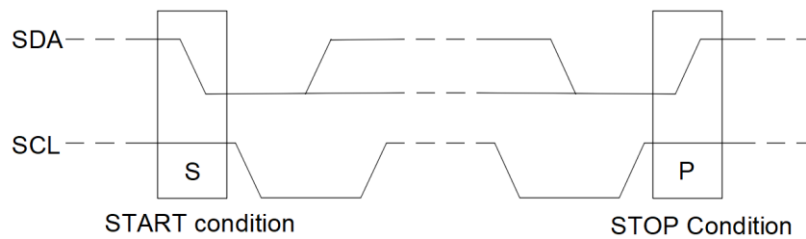

Figure 8 start and end signals.

When SDA signal switches from high to low while SCL is at a high level, it is the START start signal; when SDA signal switches from low to high, it is the STOP termination signal.

Bit Transmission and ACK Confirmation Bit

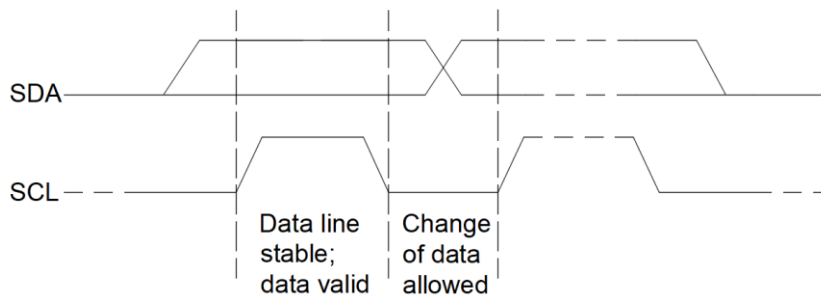

Figure 9 the bit transmission and ACK confirmation bit.

The timing sequence for bit transmission and ACK transmission is the same. Data can only be updated when SCL is at a low level, and data remains unchanged when SCL is at a high level.

4.7.3 IIC Write process

- 1) When the bus is in the "idle state" (both SDA and SCL lines are high), the master sends a start bit.
- 2) The master then sends a 7-bit device address and a 1-bit read/write control bit (R/W=0 for write).
- 3) The slave sends an acknowledgement signal (ACK=0) back to the master.
- 4) After receiving the acknowledgement signal from the slave, the master sends the register address

byte of the device.

- 5) The slave sends an acknowledgement signal (ACK) after receiving the register address.
- 6) After receiving the acknowledgement signal, the master sends the first data byte to be written.
- 7) The slave sends an acknowledgement signal (ACK) after receiving the data.
- 8) Repeating steps 6 and 7, multiple data bytes can be sequentially written to multiple registers.
- 9) The master sends a stop bit to the slave to end the communication and release the bus.

Start Signals	Subordinate device address (write)	ACK	Subordinate device Register address	ACK	Write data 1	ACK
---------------	------------------------------------	-----	-------------------------------------	-----	--------------	-----

Write data 2	ACK	...	ACK	Write data n	ACK	End Signals
--------------	-----	-----	-----	--------------	-----	-------------

4.7.4 IIC Read process

- 1) When the bus is in an “idle state” (both SDA and SCL lines are high), the host sends a start bit.
- 2) The host sends a 7-bit device address and 1-bit read/write control bit R/M (where R/W=0 for write).
- 3) The slave returns an acknowledgement signal.
- 4) The host sends an 8-bit register address.
- 5) The slave returns an acknowledgement signal.
- 6) The host sends another start bit.
- 7) The host sends a 7-bit device address and 1-bit read/write control bit R/W (where R/W=1 for read).
- 8) The slave returns an acknowledgement signal.
- 9) The slave sends data, i.e. the value in the register.
- 10) The host replies with an ACK.
- 11) Steps 9 and 10 can be repeated multiple times, i.e. sequentially reading multiple registers.
- 12) The host sends a stop bit to the slave to end the communication and release the bus.

Start Signals	Subordinate device address (write)	ACK	Subordinate device Register address	ACK	Start Signals	Subordinate device address (read)	ACK
---------------	------------------------------------	-----	-------------------------------------	-----	---------------	-----------------------------------	-----

Read data 1	ACK	...	ACK	Read data n	$\overline{\text{ACK}}$	End Signals
-------------	-----	-----	-----	-------------	-------------------------	-------------

5. Registers Description

5.1 General Registers

Table 9: General Registers

ADDR	BIT	NAME	DEFAULT	ACCESS	Description	
0x00	[7:0]	App ID	8'h00	WR	Currently running application	
					0x00	Default
					0x80	Bootloader application
					0xC0	Measurement application
0x01	[7:0]	App major version	8'h00	WR	Application major revision	
0xE0	[7:0]	EN register	8'h80		Enable register for analog device	
0xE1	[7:0]	Interrupt register	8'h00	WR	0x00 default, no interrupt 0x03 interrupt for measurement	

5.2 Registers in Bootloader mode

The following hosting features are only available under the APP ID =0x80 (Bootloader).

Table 10: Registers in Bootloader mode

ADDR	BIT	NAME	DEFAULT	ACCESS	Description
0x08	[7:0]	BL Cmd	8'h00	WR	Write: Bootloader Commands Read: Bootloader Status – anything else than 0x00 means an error
0x09	[7:0]	BL data size	8'h00	WR	Bootloader Data size in bytes
0x0A~ 0x89	[7:0]	BL data 1...128	8'h00	WR	Up to 1~128 data bytes for bootloader
0x8B	[7:0]	checksum	8'h00	WR	Checksum for Sum(Cmd + Data Size + Data) XOR 0xFF

Table 11: Bootloader Commands

Bootloader Cmd	Value	Description
RAM remap	0x11	Remap RAM to address 0
Download Init	0x14	Initialize RAM
Write RAM	0x41	Write RAM Region (Plain = not encoded into e.g. Intel Hex)
RAM address	0x43	Set the read/write RAM pointer to a given address

5.3 Registers in APP0 mode

The following hosting features are only available under the APP ID =0xC0 (APP0).

Table 12: Registers in APP0 mode

ADDR	BIT	NAME	DEFAULT	ACCESS	Description
0xC7	[7:0]	Temperature threshold	8'h00	WR	If variation between current temperature and temperature of last calibration is bigger than this threshold, calibration will be performed
0xD7~ 0xD8	[7:0]	Global offset	8'h00	WR	Global offset is calculated by global offset calibration. If offset is negative, the required data format is binary complement 0xD7: 1LSB = 1mm 0xD8: 1LSB = 256mm

Table 13: APP0 command

ADDR	App0 Cmd	Value	Description
	Ranging	0x04	Single or continuous measurement
	Standby	0x12	Turn off oscillator and CPU, but RAM is power on
	Reset	0x13	Reset CPU, RAM and IIC registers
	Stop measurement	0xFF	Stop measurement or reading histogram

Register setting for ranging Mode: App0 Cmd = 0x04

ADDR	BIT	NAME	DEFAULT	ACCESS	Description
0x06	[7:0]	Cmd data 9	8'h00	WR	Flag for continuous measurement 0x00: default, single measurement 0x02: continuous measurement
0x07	[7:0]	Cmd data 8	8'h00	WR	Repetition period in mSec, If the repetition period is set lower than the ranging time for this mode, the SOT26-001 runs at maximum possible speed 0x00: default 0x23: For fps 30Hz on continuous measurement
0x08	[7:0]	Cmd data 7	8'h00	WR	Frame count 0x00: default 0x20: 32 frame for Fixed frame mode
0x09	[7:0]	Cmd data 6	8'h00	WR	Iterations of self-calibration 1 LSB = 1 k
0x0A~	[7:0]	Cmd data 5/4	8'h00	WR	Iterations of main-lighting

0x0B					0x0A: 1 LSB = 256 k 0x0B: 1 LSB = 1 k
0x0C~ 0x0D	[7:0]	Cmd data 3/2	8'h00	WR	Iterations of pre-lighting 0x0C: 1 LSB = 256 k 0x0D: 1 LSB = 1 k
0x0E	[7:0]	Cmd data 1	8'h00	WR	High period of single lighting 1 period = 1 PLL clock
0x0F	[7:0]	Cmd data 0	8'h00	WR	Sum period of single lighting 1 period = 1 PLL clock

ADDR	BIT	NAME	DEFAULT	ACCESS	Description
0x20	[7:0]	Result Num.	8'h00	WR	Result number, incremented every time after measurement
0x21- 22	[7:0]	Distance	8'h00	WR	Distance in [mm] of the object 0x21: 1LSB = 1mm 0x22: 1LSB = 256mm
0x23	[7:0]	Confidence	8'h00	WR	Reliability of object
0x24~ 0x27	[7:0]	Sys_tick	8'h00	WR	The sys clock registers[32 bits] is a running timer information – this value is counting up (and wraps around to 0 again) as long as the internal clock is running 0x24: sys_tick[7:0] 0x25: sys_tick[15:8] 0x26: sys_tick[23:16] 0x27: sys_tick[31:24]
0x28~ 0x2F	[7:0]	Algo. State	8'h00	WR	Algorithm state for current result
0x30	[7:0]	Temperature	8'h00	RO	Temperature in chip

6. Application information

6.1 Module dimensions

The SOT26-001 is a 12 Pin LGA package with plastic lid. Its dimensions are 4.4mm (± 0.05 mm) x 2.4mm (± 0.05 mm) x 1.00mm (± 0.075 mm). Tolerance is ± 0.05 mm unless otherwise specified.

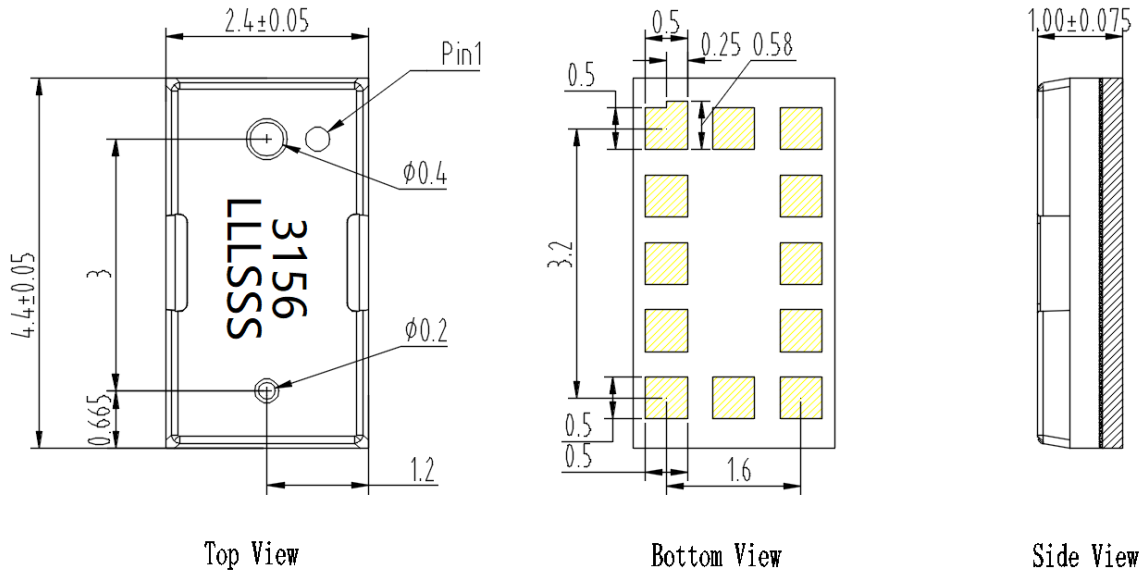
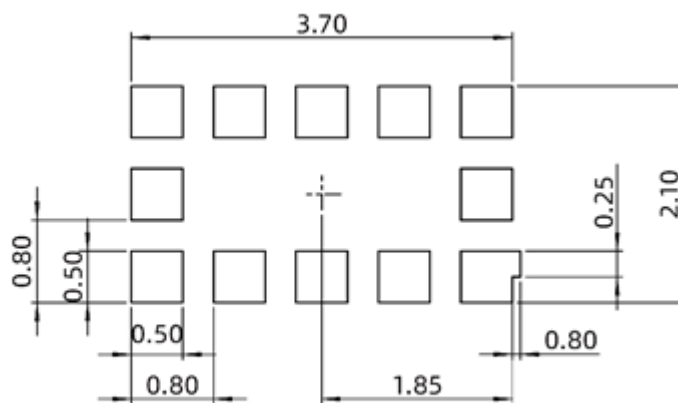

Figure 10: SOT26-001 outline dimension

6.2 PCB pad layout



Note:
- All dimensions are in mm unless otherwise specified.

Figure 11: PCB footprint (top view)

6.3 Application schematic

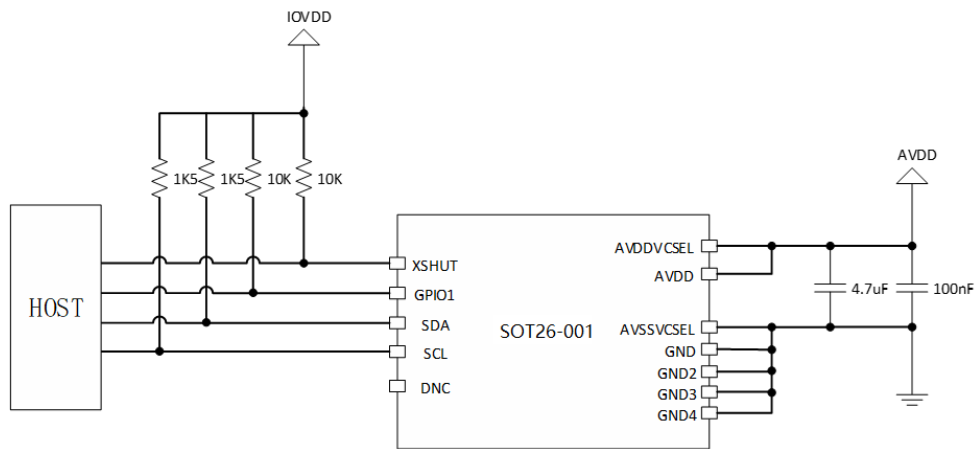

Figure 12: SOT26-001 schematic

Note:

- The capacitors on the external AVDD should be as close as possible to the AVDDVCSEL and AVSSVCSEL module pins;
- The HOST must always drive XSHUT. If the host status is unknown, you need to pull up. XSHUT requires the use of LW standby mode (no IIC communication).

7. Soldering and storage

7.1 Manufacturing and soldering

It is suggested that the peak reflow temperature is 240°C ~ 260°C and the absolute maximum reflow temperature is 260°C. The recommended reflow soldering thermal profile (lead-free reflow soldering) and related parameters are shown below:

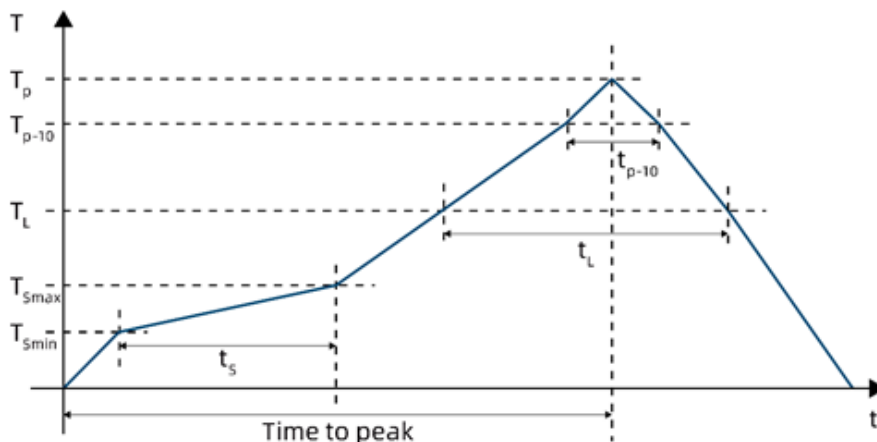

Figure 13: Recommended reflow soldering thermal profile

Table 14: Recommended thermal profile parameters

Parameter	Recomm. value	Max. value	Unit
Minimum temperature (T_{Smin})	130	150	°C
Maximum temperature (T_{Smax})	200	200	°C
Time t_S (T_{Smin} to T_{Smax})	90-110	60 - 120	s
Temperature (T_L)	217	217	°C
Time (t_L)	55-65	55 - 65	s
Ramp up	+2	+3	°C/s
Temperature (T_{p-10})	-	250	°C
Time (t_{p-10})	-	10	s
Ramp up	-	+3	°C/s
Peak temperature (T_p)	240	260 max.	°C
Time to peak	300	300	s
Ramp down (peak to T_L)	-4	-6	°C/s

Note:

- Temperature mentioned in the table above is measured at the top of the device package.
- The component should be limited to a maximum of 3 passes through this solder profile.

7.2 Storage information

The SOT26-001 is delivered in sealed moisture-barrier bags. It has been assigned a moisture sensitivity level of MSL 3. The following storage conditions must be noted:

Moisture Sensitivity

Optical characteristics of the device can be adversely affected during the soldering process by the release and vaporization of moisture that has been previously absorbed into the package.

To ensure the package contains the smallest amount of absorbed moisture possible, each device is baked prior to being dry packed for shipping. Devices are dry packed in a sealed aluminized envelope called a moisture-barrier bag with silica gel to protect them from ambient moisture during shipping, handling, and storage before use.

Shelf Life

The calculated shelf life of the device in an unopened moisture barrier bag is 12 months from the date code on the bag when stored under the following conditions:

- Shelf Life: 12 months
- Ambient temperature: $\leq 40^\circ\text{C}$
- Relative humidity: $\leq 90\%$

Re-baking of the devices will be required if the devices exceed the 12 months shelf life or the Humidity

Indicator Card shows that the devices were exposed to conditions beyond the allowable moisture region.

Floor Life

The SOT26-001 is rated at MSL 3. As a result, the floor life of devices removed from the moisture barrier bag is 168 hours from the time the bag was opened, provided that the devices are stored under the following conditions:

- Floor Life: 168 hours
- Ambient temperature: $\leq 30^{\circ}\text{C}$
- Relative humidity: $\leq 60\%$

If the floor life or the temperature/humidity conditions have been exceeded, the devices must be re-baked prior to solder reflow or dry packing.

Re-baking Instructions

The re-baking conditions are as follows:

- 125 ± 5 degrees Celsius for 8 hours;
- The product cannot be baked directly in the carrier tape;
- Avoid excessive vibration or impact to prevent serious deformation or damage of packaging material.

8. Package Specifications

8.1 Tape Specifications

Quantity per reel: 4500pcs.

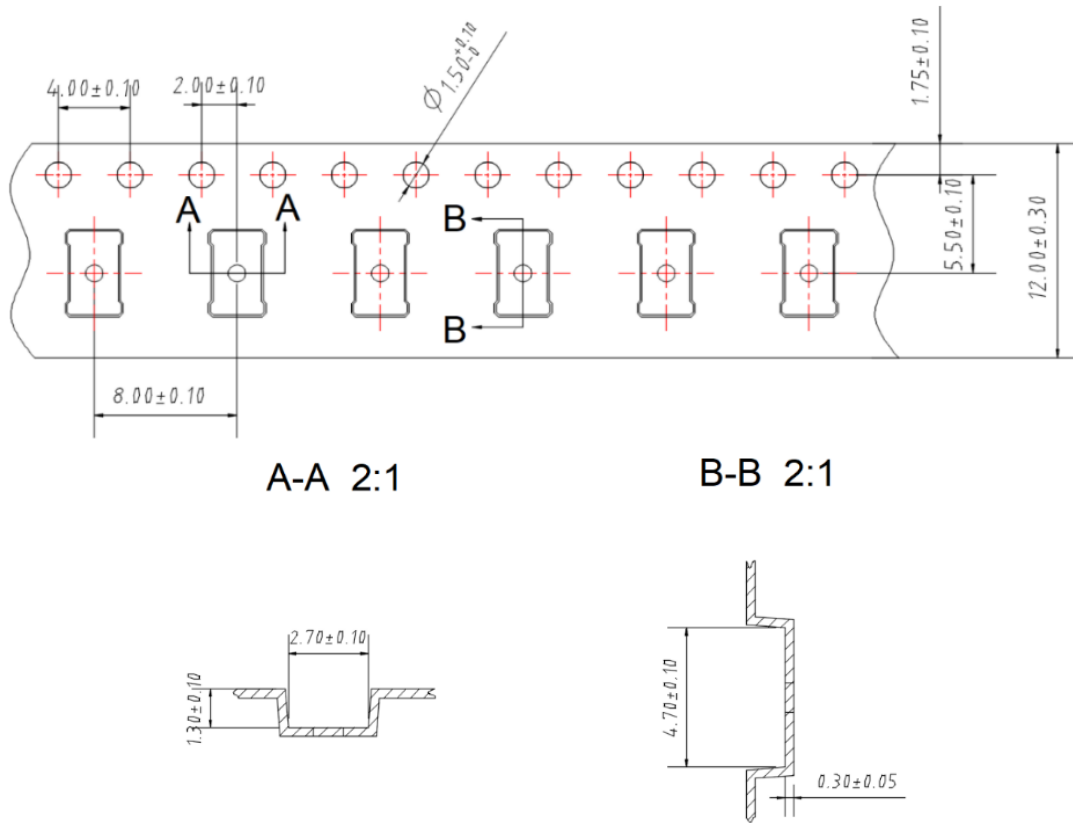

Figure 14: Tape Information (Unit: mm)

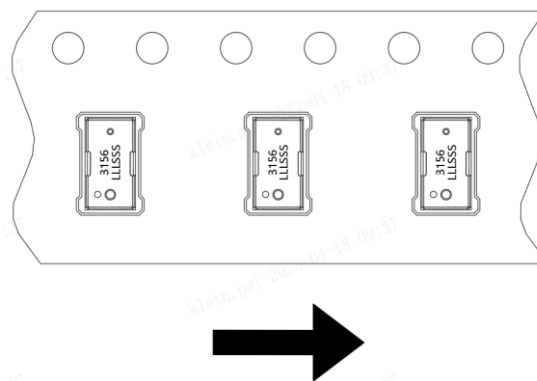
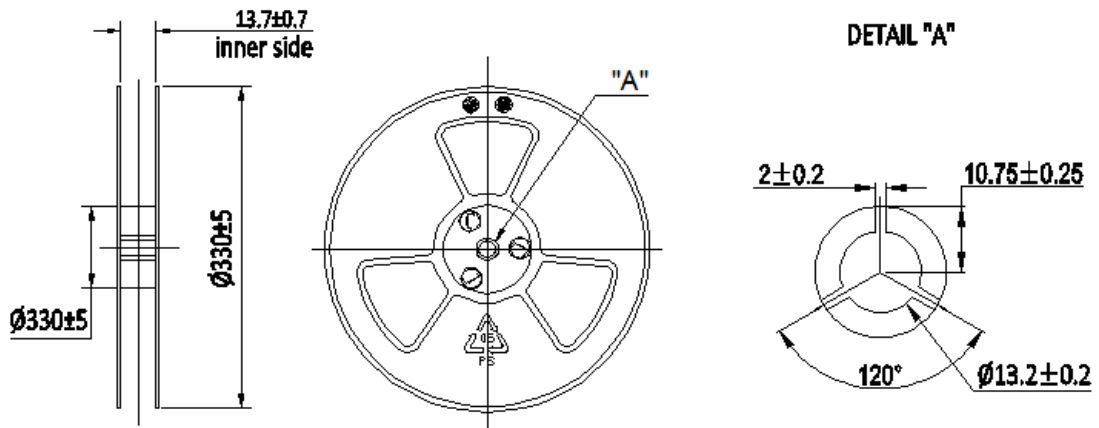

Figure 15: Pin Information

8.2 Reel Specification

13" reel will be provided for mass production stage and sample stage more than 1000pcs

13" Reel Specification (Unit: mm)



8.3 The content of Box

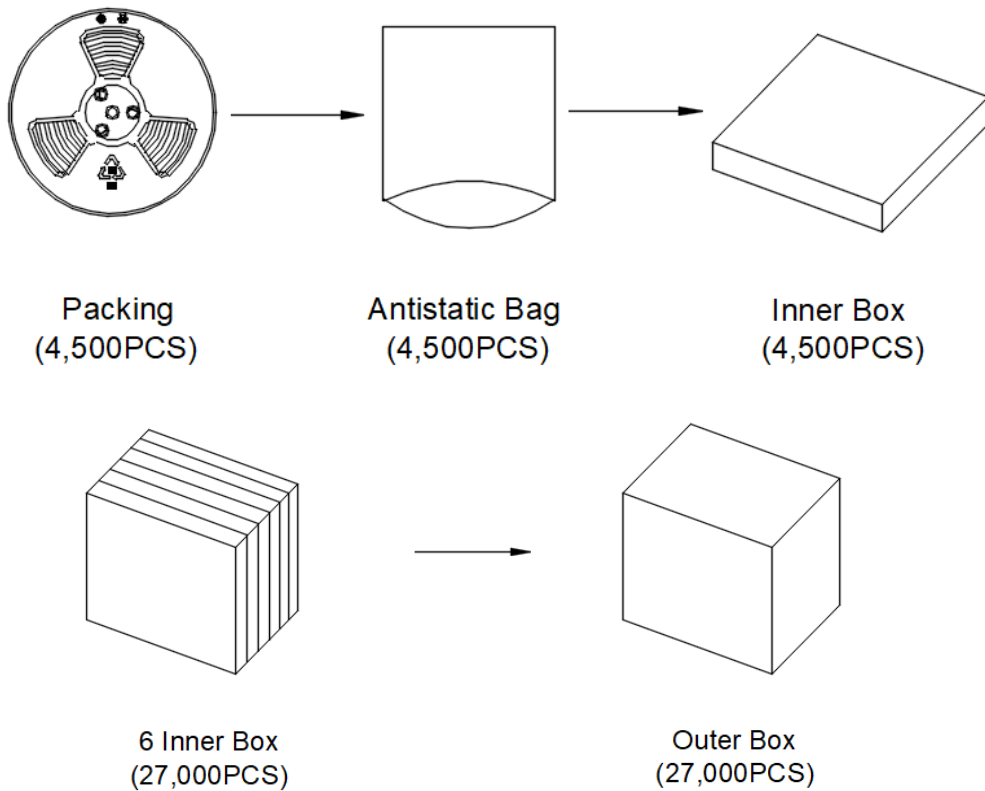

8.4 Packing Explain

The Label Content of the Reel

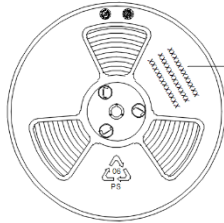

The Content Includes:
RoHS+HF, MSL:3;
Product type, Lot, Customer P/N;
and other essential information such as
Quality, Date etc.

The Label Content of ESD Caution

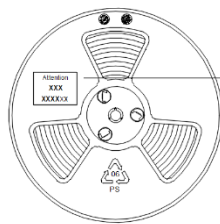

ESD Caution Label

The Label Content of Moisture Caution

Moisture Caution: MSL 3

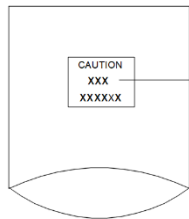

MSL 3 Caution Label

9. Laser eye safety

The SOT26-001 is designed to meet the Class 1 laser safety limits including single faults in compliance with IEC / EN 60825-1:2014. This applies to the stand-alone device and the included software supplied by Goermicro. In an end application system environment, the system may need to be tested to ensure it remains compliant. The system must not include any additional lens to concentrate the laser light or parameters set outside of the recommended operating conditions. Use outside of the recommended condition or any physical modification to the module during development could result in hazardous levels of radiation exposure.



10. Acronyms and abbreviations

Table 15: Acronyms and abbreviations

Abbr.	Definition
ESD	Electrostatic discharge
I ² C	Inter-integrated circuit (serial bus)
SPAD	Single photon avalanche diode
SPI	Serial Peripheral Interface
VCSEL	Vertical cavity surface emitting laser
ToF	Time of Flight
dToF	Direct Time of Flight
FoV	Field of view